

Polaris PQ-512/85 AAA

512-Channel
Ink Jet Printhead

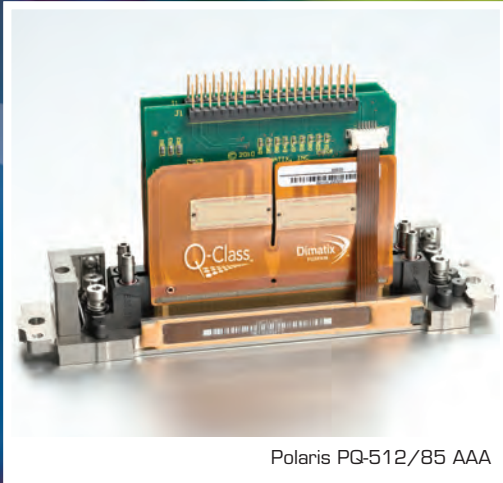

Polaris PQ-512/85 AAA

Features:

- 80 picoliter nominal drop size
- 512 individual addressable nozzles
- Incorporates VersaDrop™ binary jetting capability
- Excellent channel-to-channel uniformity
- High frequency continuous operation
- Designed for long service life
- Supports UV-curable, solvent, and aqueous-based inks
- Configurable for single- and two-color operation
- Integral mounting bezel with precision features
- Optimized for high viscosity jetting fluids
- Built-in heaters and temperature sensors
- Operation up to 60°C (140°F)
- Simplified field repair with no special tools required

The Spectra® Polaris PQ-512/85 AAA is a high performance inkjet printhead designed for a broad range of industrial and commercial printing applications at resolutions up to 400 dpi. Robust construction and repairable design make it ideal for solvent, UV and aqueous based wide format printers built for demanding production environments.

Building upon the legendary reliability and performance of the Spectra Nova and Galaxy printheads, the Polaris PQ-512 AAA family of printheads uses field proven materials and a repairable design to deliver a long service life and consistent output. And by leveraging the inherent flexibility of the Q-Class platform, the Polaris PQ-512 AAA offers even greater jetting performance, nozzle packing density, and configuration flexibility.

The Polaris PQ-512/85 AAA Printhead has 512 independent channels arranged in multiple rows at 200 dots-per-inch spacing for single color operation, or 100 dots-per-inch spacing for two color operation. The printhead is designed for binary jetting using a 80-picoliter native drop size with 8-meters per second nominal drop velocity for jetting fluids in the 10 to 14 centipoise range. Using VersaDrop jetting technology, the printhead is capable of adjustable binary operation at drop sizes up to 150 picoliters.

The PQ-512/85 AAA Printhead is compatible with a broad range of inks, including UV-curable, aggressive organic solvent and aqueous inks and associated maintenance fluids.

The unique design of Polaris PQ-512/85 AAA Printhead allows each 256-channel module to be replaced and accurately registered in the field with no special tools or recalibration. An integral mounting bezel with precision registration points enables drop-in alignment with other carriage features.

Two electrical connectors contain eight serial data lines that support fire frequencies in excess of 50 kHz.

The flexible fluid interface allows single and two-color operation. Each 256-channel module is dual ported to facilitate easy priming, flushing and ink recirculation. Heaters and temperature sensors allow precise control of ink viscosity at jetting temperatures up to 60°C.



www.dimatix.com



Parameter	Polaris PQ-512/85 AAA						
Number of addressable jets	512						
Print width	64.897 mm (2.555 inches)						
NOZZLE SPACING:							
Single color (4 rows of jets)	127 microns [0.005 in.] (200 dpi)						
Two color (2 rows of jets/per color)	254 microns [0.010 in.] (100 dpi)						
Jet straightness, 1 sigma*	2.0 mrad [0.11°]						
Nominal drop velocity	8 m/s						
Calibrated drop mass	80ng						
Compatible jetting fluids	UV-curable, organic solvents, aqueous						
BINARY OPERATION:							
Adjustment for drop size	80 - 150 picoliters						
Productivity	<table border="1"> <thead> <tr> <th>Drop Size</th> <th>Maximum Frequency</th> </tr> </thead> <tbody> <tr> <td>80 pl</td> <td>20 kHz</td> </tr> <tr> <td>150 pl</td> <td>10 kHz</td> </tr> </tbody> </table>	Drop Size	Maximum Frequency	80 pl	20 kHz	150 pl	10 kHz
Drop Size	Maximum Frequency						
80 pl	20 kHz						
150 pl	10 kHz						
Operating temperature range	up to 60° C						
Fluid viscosity at jetting	10 to 14 centipoise						
Dry weight	160 grams						

*typical

Physical Characteristics

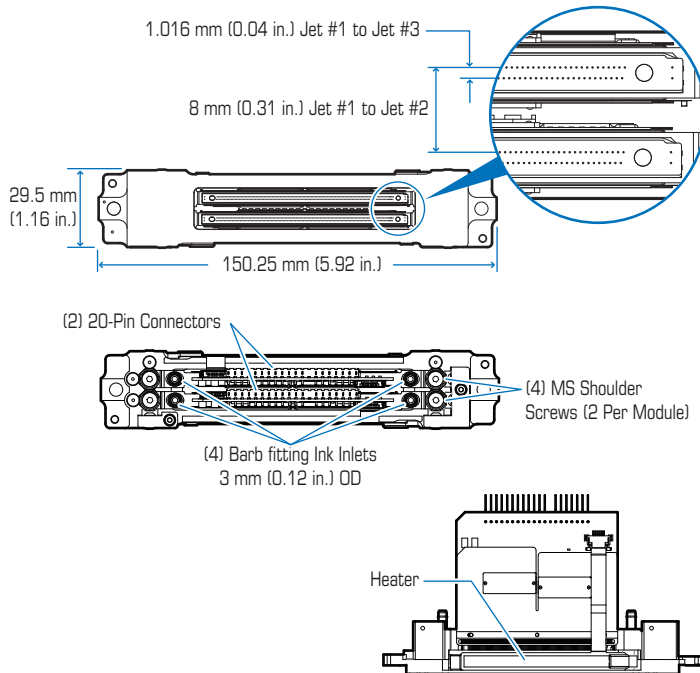

Jetting Characteristics

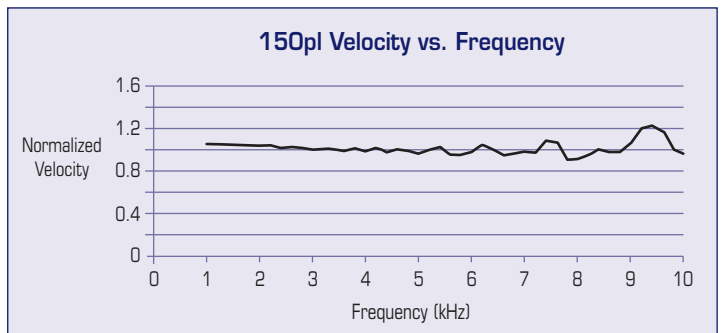
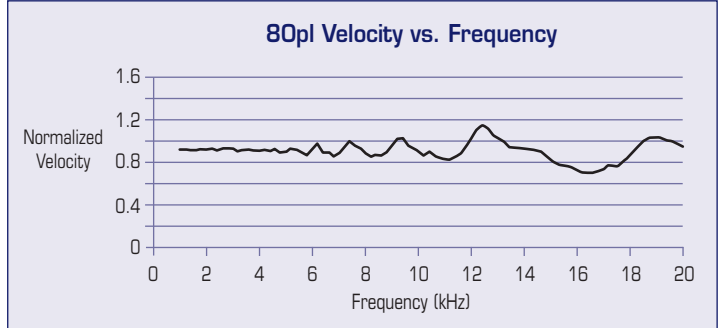

Product data presented above are for guideline purposes only. For design and engineering work using this product, please contact Dimatix Technical Support for the appropriate Product Manual containing full Product Specifications.



Corporate Office:
FUJIFILM Dimatix, Inc.
2230 Martin Avenue
Santa Clara, CA 95050
USA

Tel: (408) 565-9150
Fax: (408) 565-9151
Email: info@dimatix.com

New Hampshire Facility:
FUJIFILM Dimatix, Inc.
109 Etna Road
Lebanon, NH 03766
USA

Tel: (603) 443-5300
Fax: (603) 448-9870
Email: info@dimatix.com

Japan Office:
Advanced Marking Business Division
FUJIFILM Corporation
Midtown West, 7-3, Akasaka 9-Chome
Minato-ku, Tokyo 107-0002
Japan

Tel: +81 3 6271 1091
Fax: +81 3 6271 1165
E-mail: front.ambd@fujifilm.co.jp

European Office:
Tel: +44 7739 863 505
Fax: +44 870 167 4328
Email: euro@dimatix.com

Korean Office:
Tel: +82 2 6242 6012
Fax: +82 2 6242 6012
Email: korea@dimatix.com

China Office:
Email: china@dimatix.com